



80 YEARS OF CORROSION PROTECTION

APPLICATION INSTRUCTIONS

Steelcoat 400 System

1. SYSTEM:

The system consists of Denso bitumen tapes, primers, putty and topcoat providing long term corrosion protection. To protect the substrate from corrosion the system completely encases and segregates its surface from the surrounding environment by making intimate contact with the entire exposed substrate.

2. USES:

For the protection of structural steel, steel fittings and similar structures from corrosion above ground in harsh climatic or industrial environments.

3. EQUIPMENT LIST:

These items may be required;

Power wire brush and spare brushes, scraper, chipping hammer, scrubbing brush, blast cleaning equipment (optional). Paint brush, brush cleaning solvent. Utility knife, tape measure, cutting board, fluted roller. Overalls, gloves, safety glasses, safety boots, cleaning cloth, hand cleaner, barrier cream. If necessary hard hats, scaffolding / safety belt.

4. COMPONENTS LIST:

- | | |
|-------------------------|---------------------|
| • Denso Primer D | Additional Options: |
| • Denso Bitumen Putty | • Denso D5 Scrim |
| • Denso Conforming Tape | • Denso ST Epoxy |
| • Denso Ultraseal Tape | |
| • Denso Acrylic Topcoat | |

Components should be stored at a minimum of 12°C, for at least 24 hours, prior to use. Refer to Denso Technical Data Sheets for specific details of individual components.

5. APPLICATION of SYSTEM:

a) Surface Preparation:

Remove all dirt and salt deposits by washing with fresh water. Allow substrate to dry then remove all scale, loose rust and old flaking coatings by power wire brush to achieve a minimum finish of St2 according to ISO 8501-1 or Swedish Standard SIS 0055900. Where mill scale is present abrasive blasting is required to an Sa2½ profile finish. Solvent wipe with a clean cloth to remove any grease deposits.

Surface Chloride levels should be less than 50µm/cm² before proceeding.

It is preferable for the ambience and substrate temperatures to be ≥5°C before proceeding to apply the components.

b) Priming - Denso Primer D:

Brush apply a uniform coat of Denso Primer D over the entire area to be protected. Ensure the primer saturates any pitted imperfections in the substrate. Coverage rate: 5m²/L. Allow primer solvent to evaporate and leave behind a tacky bonding agent, then proceed.

c) Filling - Denso Bitumen Putty:

For deep pitting where there is a danger of applied tapes “bridging” and leaving behind air pockets Denso Bitumen Putty is used to prepare a profile suitable for the application of the tape.



▲ Fig 1. Steelcoat 400 protects all areas, including hand rails, of badly rusted / pitted gantry crane situated in a nuclear power plant. Conventional paint coating failed after only 4 years service.

5. APPLICATION of SYSTEM (continued):

d) Denso Conforming Tape:

Strips of 50mm wide Conforming Tape are first applied into all internal corner sections. After positioning, overwork with the handle of a utility knife or blocking tool to ensure there is no bridging of the tape. Joins should be butt jointed and not overlapped.

Pre-cut strips of Conforming Tape from the roll to suit particular requirements of any awkward shape. Ensure that the interleaving is removed from the compound side of the roll before application. Once applied, work with finger pressure to ensure full contact to primed steel and putty. Remove protective film from the backing to expose glass mesh reinforcement and adhesive before application of the next strip of Conforming Tape. The tape is to be butt jointed (not overlapped) at the ends.

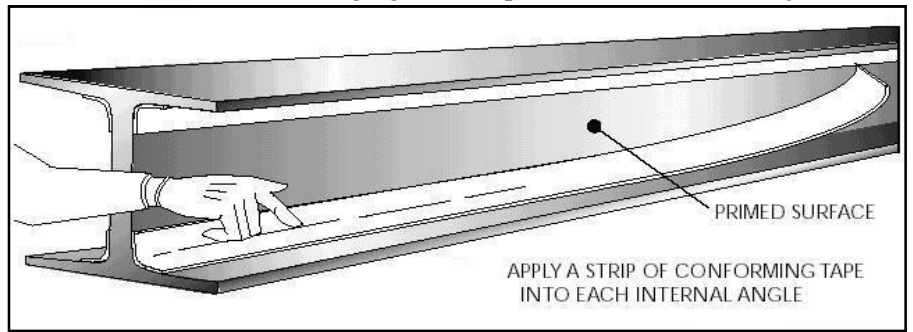

▲ Fig 2. Application and positioning of Conforming tape on Rolled Steel Joist (RSJ) beams.

At rivet heads, nuts and bolts etc make two cuts in the Conforming Tape in the form of a cross over the rivet or bolt. Press the tape down thoroughly around the head and apply a small patch of tape to cover the rivet or bolt with at least 25mm overlap all round and press down.

e) Denso Ultraseal Tape:

Remove interleaving on applied Conforming Tape before application of Ultraseal Tape.

Apply Denso Ultraseal Tape in lengths of one metre maximum. The size of the tape is measured in accordance with the size of the steelwork member and cut accordingly.

Choose widths of tape that permit overlaps of at least 25mm and ensure overlaps are applied in a 'weatherboard' fashion. Always work from the bottom upwards. Avoid overlapping the tape on the underside of horizontal surfaces.

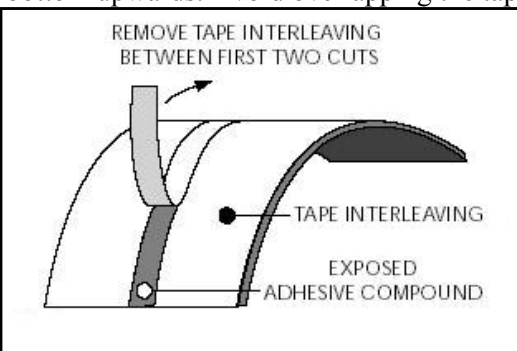

◀ Fig 3. Removing interleaving from Ultraseal Tape to expose central strip of adhesive compound.

- Working from the bottom upwards, measure and cut a tape piece long

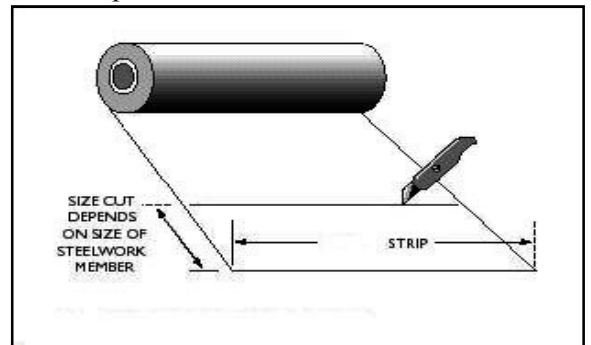

▲ Fig 4. Unrolling and preparing a strip of Ultraseal

▼ Fig 5. Cross section diagram highlighting the correct sequence for applying the primer and tapes to an RSJ beam.

enough to fold around the whole base and continue upwards to a minimum point of 25mm up the two vertical faces of the steel.

- Cut away and remove a 10mm strip of the interleaving layer lengthwise down the middle of the tape exposing the adhesive compound underneath (see Fig 3).
- Carefully place and centralise the piece of tape on the section of steel. Firmly smooth down the exposed adhesive compound. With both hands now free the sections of interleaving paper can now be removed from either side of the bonded adhesive compound. The tape is then smoothed down onto the steel section by hand without overstretching the tape by using a downward and outward motion from the centre to expel all air and form an intimate bond (see Fig 6).
- The tape should be smoothed in to the corner sections to ensure full bond to the Conforming Tape.
- Overwork tape with fluted roller to ensure there are no trapped air pockets.



◀ Fig 6. Ultraseal Tape: centralise over area to be protected and press down firmly to form a bond, removing interleaving as you progress.

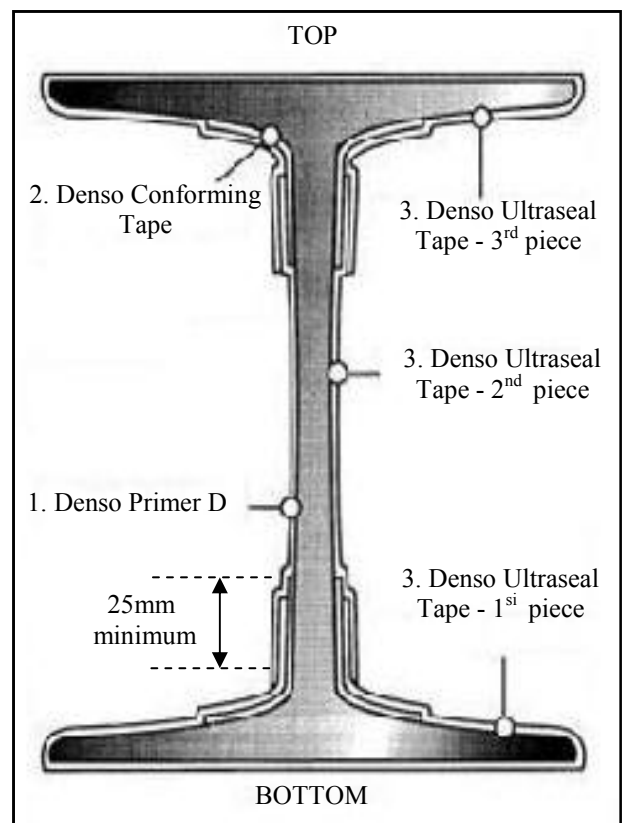

5. APPLICATION of SYSTEM (continued):

e) Denso Ultraseal Tape (continued):

- Measure up and cut tape for the next section. The end of the tape should overlap onto the previous tape piece by 25mm. All overlaps must be thoroughly overworked with a fluted roller to ensure a waterproof seal is achieved.
- The final piece of tape should be long enough to cover the complete top section and continue down the vertical section to a point where it overlaps a minimum 25mm over previous layers.

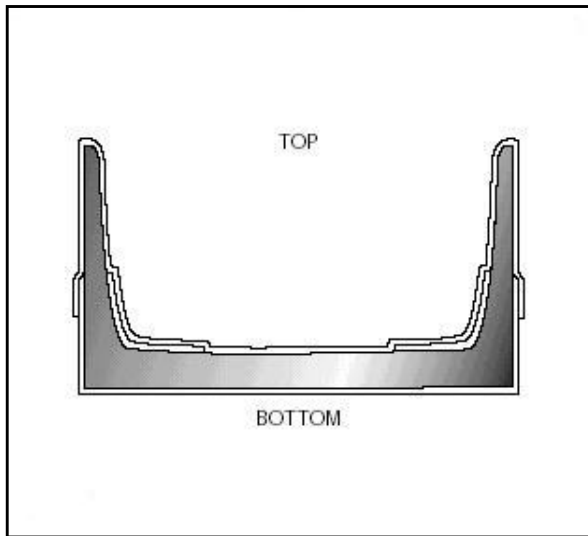

◀ **Fig 6.**
The correct tape configuration for steel channels

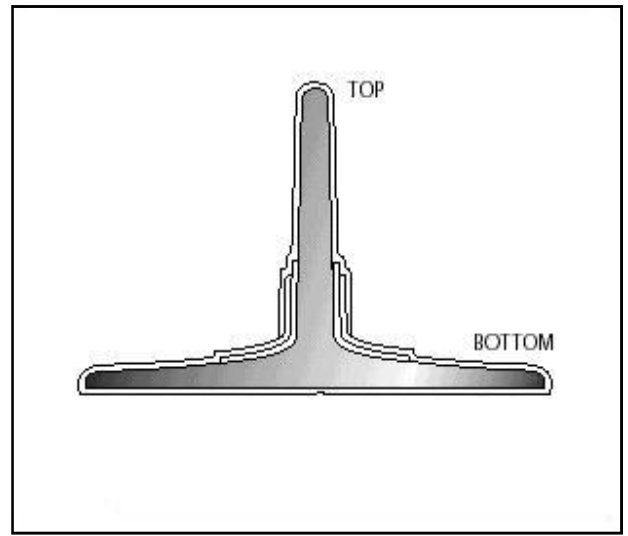

▶ **Fig 7.**
The correct tape configuration for steel tee beams

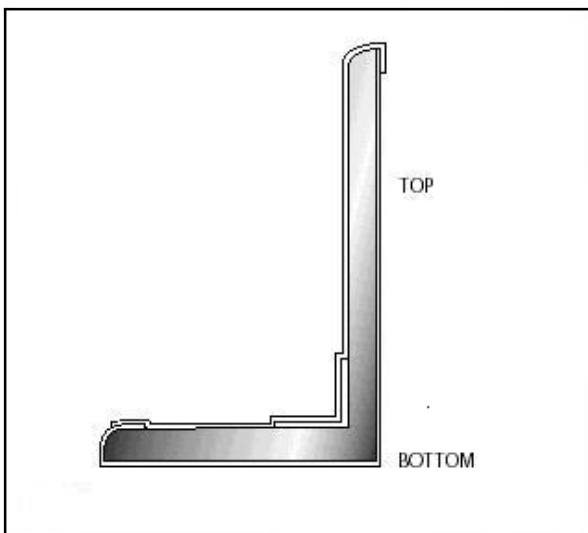

◀ ▶ **Fig 8 & 9.**
The correct tape configuration for steel angle beams

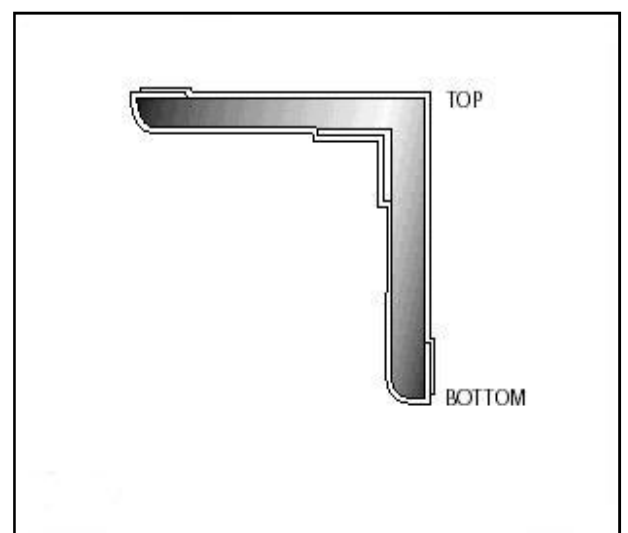

f) Overcoating:

Once the structure is taped it must be overcoated with a brush or roller application of either Denso Acrylic Topcoat or Denso ST Epoxy at a coverage rate of 0.33L/m².

g) Additional Reinforcement:

For areas where extra mechanical protection or optimum maintenance free service life is required, Denso D5 Scrim is fully saturated with the selected topcoat.

First apply a thick layer of the topcoat to the Ultraseal Tape and then 'wet in' the scrim. The D5 Scrim is applied in pre-cut lengths, similar in size to the Ultraseal Tape application.

D5 Scrim absorbs a minimum of 0.5L/m² of topcoat.

6. REPAIRS TO DAMAGED COATINGS:

Cut away and remove loose coating from damaged area and smooth or chamfer edges. Clean area thoroughly then prime the exposed substrate or surface extending 50mm either side of the damage. Repair the damaged area with a patch of conforming tape. Seal with a length of Ultraseal Tape then overcoat with a protective Denso Acrylic Topcoat or Denso ST Epoxy.

7. INSPECTION:

Ensure that the entire surface is encased / covered with no gaps or air pockets. Holiday testing can be conducted to locate any flaws in the applied system at 15kV maximum.

8. SAFETY DATA:

Storage:	Store right way up in original packaging. Store away from heat, direct sunlight and open flames.
Transport:	Avoid prolonged exposure to high temperatures during transit, preferably in an enclosed vehicle.
Handling:	Grease resistant gloves may be worn to reduce skin contact. Avoid contact with eyes.
Action in case of fire:	Extinguish with water fog, dry powder, carbon dioxide or chemical foam. Self-contained breathing apparatus may be needed for large fires.
Skin Contact:	Wash with warm water and mild soap. Use pumiced heavy duty hand cleaner for stubborn stains.
Swallowing:	If feeling unwell, seek medical advice
Inhalation:	Not considered likely, except in fires avoid inhaling fumes.
Spillage:	Tapes not considered hazardous. Pick up and collect material by hand. Primer and Overcoats wear gloves and eye protection then soak up with rags or sponges. Allow to dry before sending to landfill.
Disposal:	Incineration or landfill in accordance with local regulations.
Other:	For more information please refer to Denso safety data and technical data sheets. Available for all system components.

Approved Quality
Management System
AS/NZS ISO 9001:2008
Lloyds Register
Certificate N^o Mel 0927759



Denso (Australia) Pty Ltd

411 -413 Victoria Street, Brunswick Vic 3056, Australia

MELBOURNE ♦ SYDNEY ♦ ADELAIDE ♦ BRISBANE ♦ PERTH

Tel: + 61 3 93567600 or 1300 658 590 (toll free) ♦ Email: denso@densoaustralia.com.au ♦ Web: www.densoaustralia.com.au

Denso (New Zealand) Limited

Tel: + 64 21 304 660 ♦ Email: info@denso.co.nz

A MEMBER OF WINN & COALES INTERNATIONAL

