

STEELCOAT 400™ SYSTEM



A reinforced tape system for the protection of above ground pipe and steelwork

The Steelcoat 400™ System, ideal for badly pitted or rusted steel structures, comprises a bitumen primer (Denso Primer D™), a fabric backed tape (Denso Ultraseal™ Tape) and a topcoat (Denso Acrylic Topcoat™ or Denso Single-Pack Elastomeric Topcoat).

After priming, Denso Bitumen Mastic™ is used to seal and profile back to back angles, voids, flanges or fittings. The final topcoat can also be reinforced with a selected reinforcing scrim (Denso D5™ Scrim) for sections of steelwork or pipework requiring additional impact resistance.

FEATURES

- Cold applied
- Surface tolerant
- Highly conformable
- Proven performance
- Easily repaired and over-coated
- Low future maintenance costs

COMPONENTS

Denso Primer D™

Denso Ultraseal™ Tape

Denso Acrylic Topcoat™

Options:

Denso Bitumen Mastic

For sealing voids and awkward shapes.

Denso D5™ Scrim

For extra reinforcement.

SURFACE PREPARATION

Minimal surface preparation required.

Surfaces must be clean and dry. Remove all loose rust, scale and flaking coatings by hand power tool.



LAYER 1:
DENSO PRIMER D™ &
DENSO ULTRASEAL™ TAPE

LAYER 2:
DENSO ACRYLIC TOPCOAT™

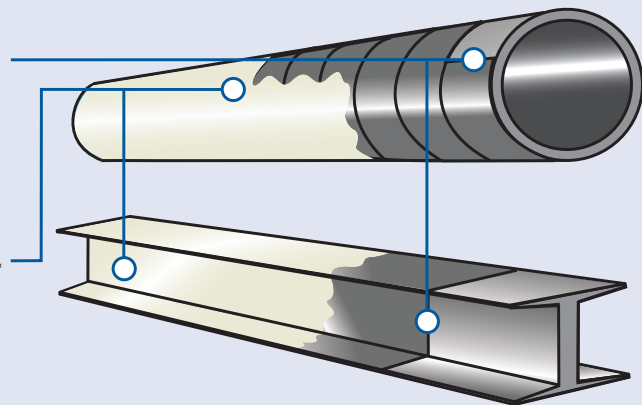

Ver 1204.22

DENSO (AUSTRALIA) PTY LTD

TEL: +61 (03) 9356 7600

FAX: +61 (03) 9356 7699

EMAIL: denso@densoaustralia.com.au

WEB: www.densoaustralia.com.au

77-95 National Boulevard

Campbellfield,

Victoria 3061

AUSTRALIA



ISO 9001:2015



A MEMBER OF WINN & COALES INTERNATIONAL