

INSTRUCTIONS FOR USE

NOTE: DENSOBAND™ SHOULD ONLY BE APPLIED IN CONJUNCTION WITH HOT LAID ASPHALT.

JOINT SURFACE

The joint surface should be sawn for preference to present an even vertical face throughout its length.

CLEANING (see Fig 1.)

Do not apply DensoBand to wet or oil contaminated surfaces.

- Ashpalt, concrete, kerbstone surfaces:
Clean with a stiff broom or wire brush to remove all dust, dirt, debris
- Metal surfaces such as road castings:
Wire brush to remove all loose rust, dirt, etc.

PRIMING (see Fig 2.)

Apply DensoBand™ Primer to the vertical joint face and allow to dry.

APPLYING DENSOBAND (see Figs 3 & 4)

- Cut DensoBand to length.
- Remove interleaving paper.
- Heat one surface of the DensoBand with a gas torch.
- Apply the molten surface to the primed face using the applicator spatula or similar tool to assist adhesion. **DensoBand should stand 5mm proud of the existing road surface. Trim flush to metal.**
- Mitre DensoBand into corners of right angle joints.

COMPACTION

After laying and levelling the new wearing course asphalt, the first pass of the roller should be along the joint edges, compacting the DensoBand to form a 'rivet head'.

HEALTH AND SAFETY ADVICE

DensoBand contains petroleum products which may affect the skin. Users are advised to:

- Ensure adequate ventilation during application.
- Wear gloves and protective clothing to protect against burns.
- Apply suitable barrier cream before working. In cases of contact with hot compound immerse in cold water.
- Wash thoroughly after use or before work breaks to remove compound from the skin.
- Avoid use of diesel or other solvents for cleaning the skin.
- Change clothing when soiled.

DensoBand Primer contains petroleum products which may affect the skin. Users are advised to:

- Avoid using in confined areas without air circulation.
- No smoking
- Use gloves. Avoid prolonged contact with the skin.
- Wash hands after use.
- Change soiled clothing.

SAFETY DATA SHEETS GIVING FULL INFORMATION ARE AVAILABLE.

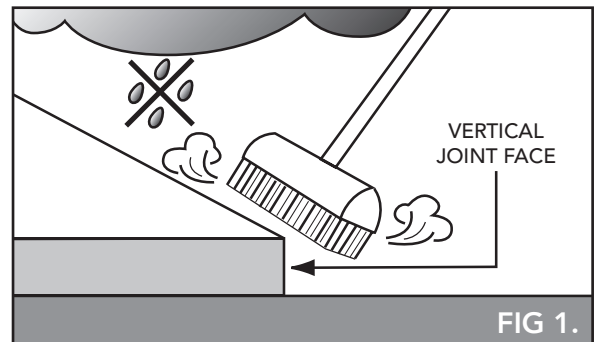

FIG 1.

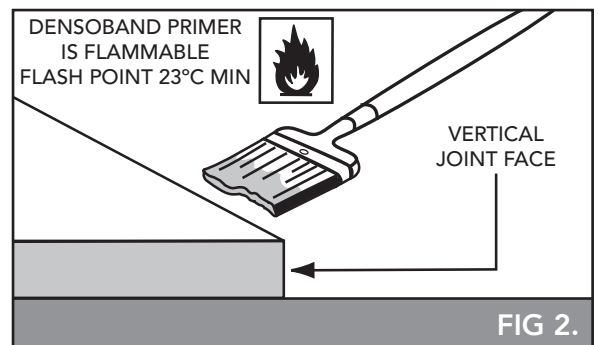

FIG 2.

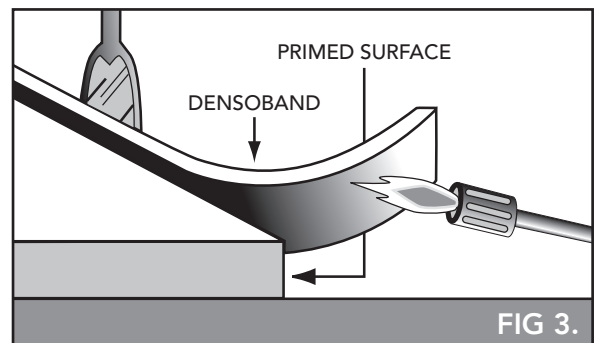

FIG 3.

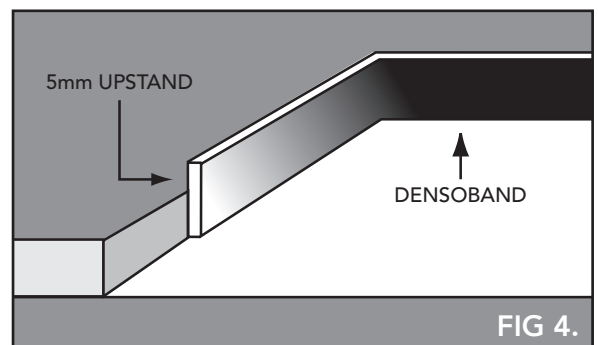

FIG 4.

IMPORTANT: Winn & Coales (Denso) Ltd pursue a policy to develop and continually improve all of our products and therefore information given in this data sheet is intended as a general guide and does not constitute a warranty or specification. However, our sales personnel are committed to assisting the user in establishing the suitability of the product for its intended purpose and additional specific information is available on request. These Instructions may not cover all circumstances and must be read in conjunction with the project specifications. For further advice contact Winn & Coales (Denso) Ltd.